

Product data sheet

Characteristics

HOM250CP

Mini circuit breaker, Homeline, 50A, 2 pole, 120/240 VAC, 10 kA AIR, standard type, plug in mount

Product availability : Stock - Normally stocked in distribution facility



Price* : 60.00 USD



Main

Product	Miniature circuit-breaker
Range	Homeline
Current Rating	50 A
Certifications	UL Listed
Voltage Rating	120/240 V AC
Mounting Type	Plug-in
Number of Poles	2P
Short Circuit Current Rating	10 kA
Number of Spaces	2
Circuit Breaker Type	Standard
Ratings	HACR rated
Electrical Connection	Box lugs
Wire Size	AWG 8...AWG 2 aluminium/copper)1
Type of Packing	Consumer packaging

Complementary

Tightening torque	40.71 lbf.in (4.6 N.m) (AWG 8...AWG 2)
Maximum Height	3.13 in (79.50 mm)
Maximum Width	2 in (50.80 mm)
Maximum Depth	2.98 in (75.69 mm)

* Price is "List Price" and may be subject to a trade discount – check with your local distributor or retailer for actual price.

Environment

Ambient Air Temperature for Operation	104 °F (40 °C)
---------------------------------------	----------------

Ordering and shipping details

Category	01346 - HOM 2 POL BULK BRKR 15-60A
Discount Schedule	CPH
GTIN	00047569062797
Nbr. of units in pkg.	5
Package weight(Lbs)	0.7 lb(US) (0.32 kg)
Returnability	Yes
Country of origin	MX

Packing Units

Unit Type of Package 1	PCE
Package 1 Height	2.00 in (5.08 cm)
Package 1 width	3.10 in (7.874 cm)
Package 1 Length	3.20 in (8.128 cm)
Unit Type of Package 2	BB1
Number of Units in Package 2	5
Package 2 Weight	3.65 lb(US) (1.656 kg)
Package 2 Height	3.10 in (7.874 cm)
Package 2 width	3.10 in (7.874 cm)
Package 2 Length	10.20 in (25.908 cm)
Unit Type of Package 3	CAR
Number of Units in Package 3	50
Package 3 Weight	36.95 lb(US) (16.76 kg)
Package 3 Height	10.50 in (26.67 cm)
Package 3 width	6.90 in (17.526 cm)
Package 3 Length	16.60 in (42.164 cm)

Offer Sustainability

Sustainable offer status	Green Premium product
REACH Regulation	REACH Declaration
REACH free of SVHC	Yes
EU RoHS Directive	Compliant EU RoHS Declaration
Toxic heavy metal free	Yes
Mercury free	Yes
RoHS exemption information	Yes
China RoHS Regulation	China RoHS declaration Pro-active China RoHS declaration (out of China RoHS legal scope)
Environmental Disclosure	Product Environmental Profile

Dimensions

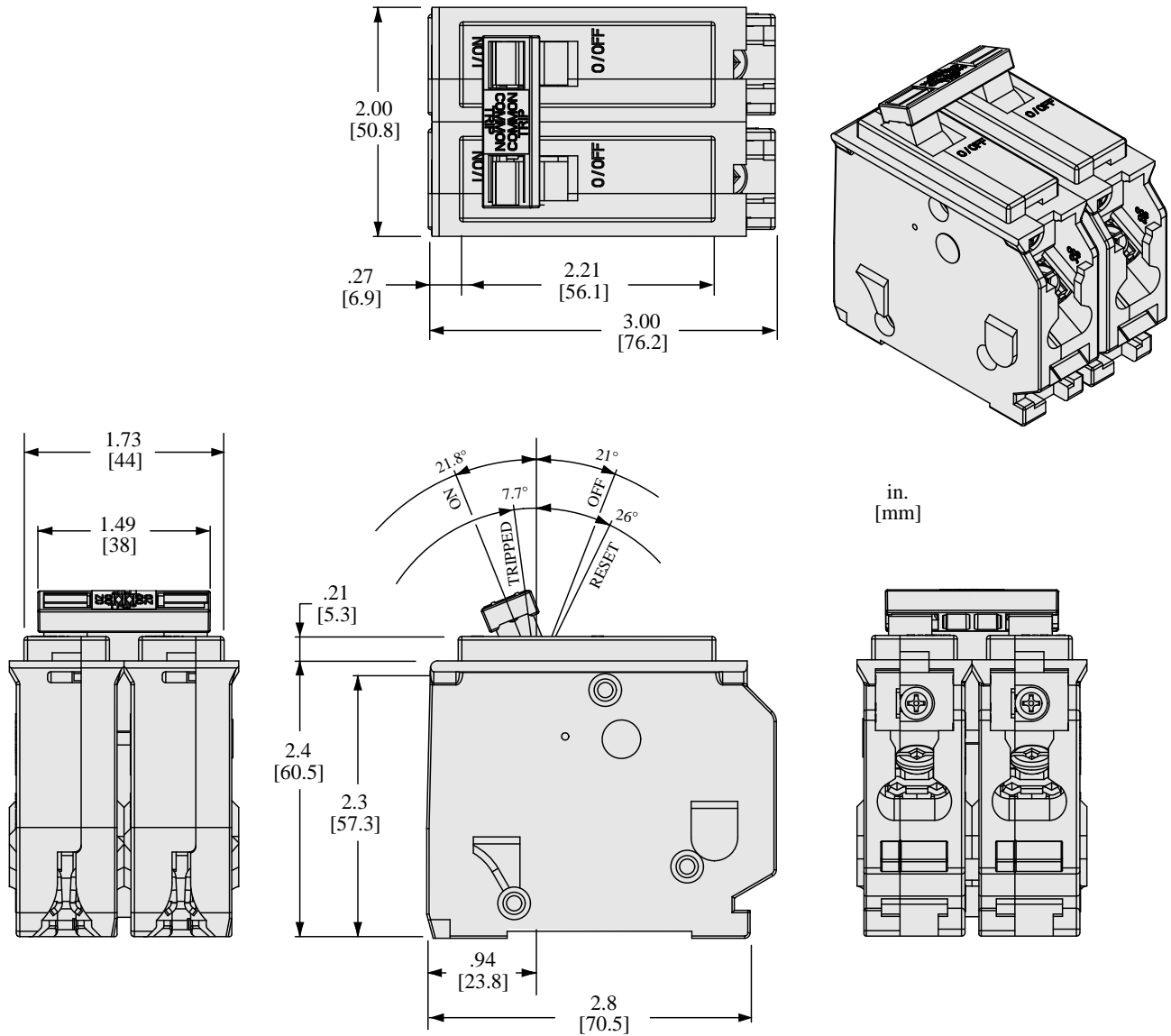

All dimensions are approximate. Also refer to technical drawings and documentation.