



SERVICE PARTS LIST

BULLETIN NO.
54-06-5100

SPECIFY CATALOG NO. AND SERIAL NO. WHEN ORDERING PARTS		REVISED BULLETIN	DATE
M18™ Compact Brushless Drill-Driver			Mar. 2022
CATALOG NO.	2801-20	STARTING SERIAL NO.	J86A
		WIRING INSTRUCTION SEE PAGE 2	

EXAMPLE:
Component Parts (Small #) Are Included
When Ordering The Assembly (Large #).

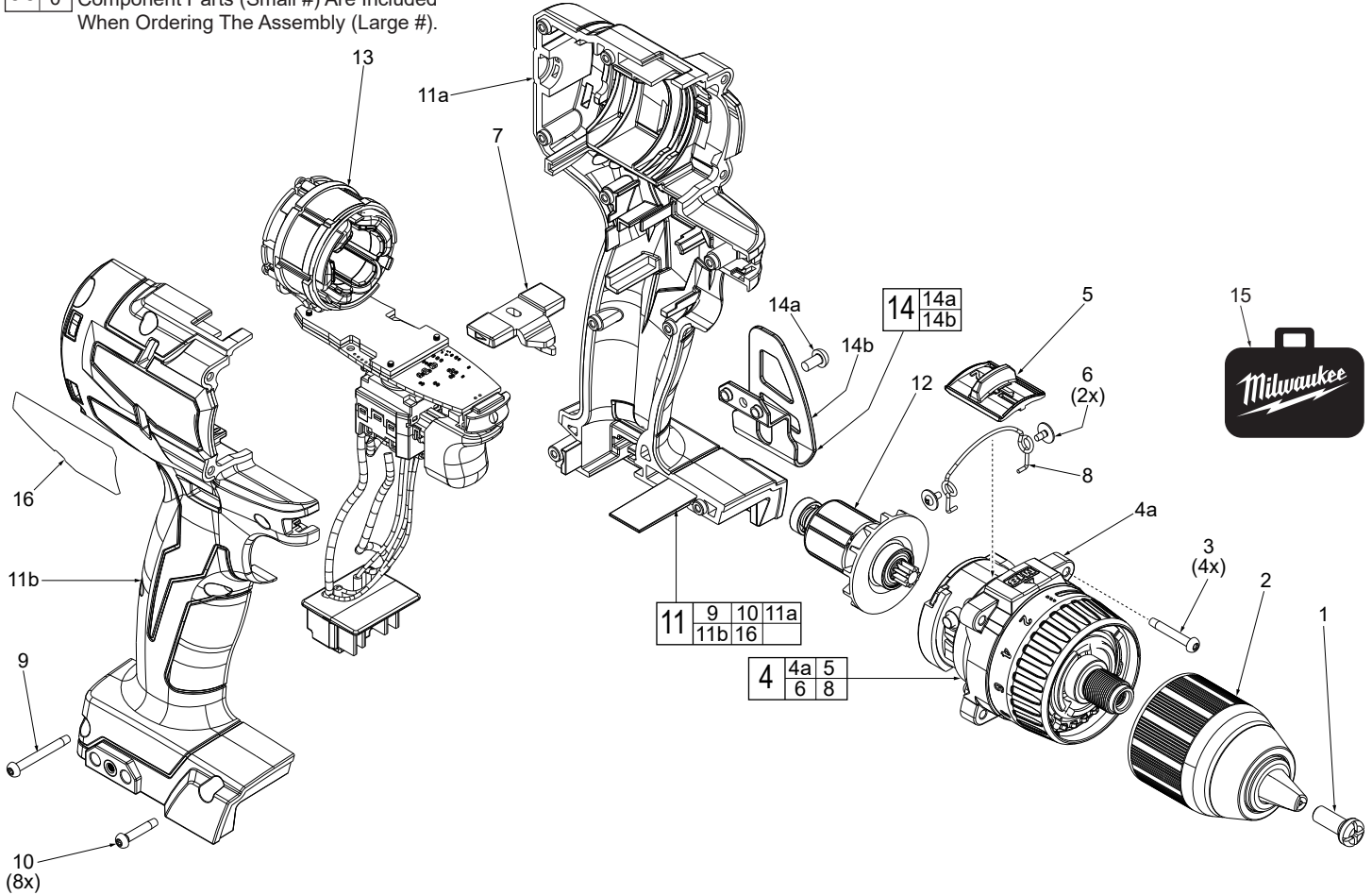
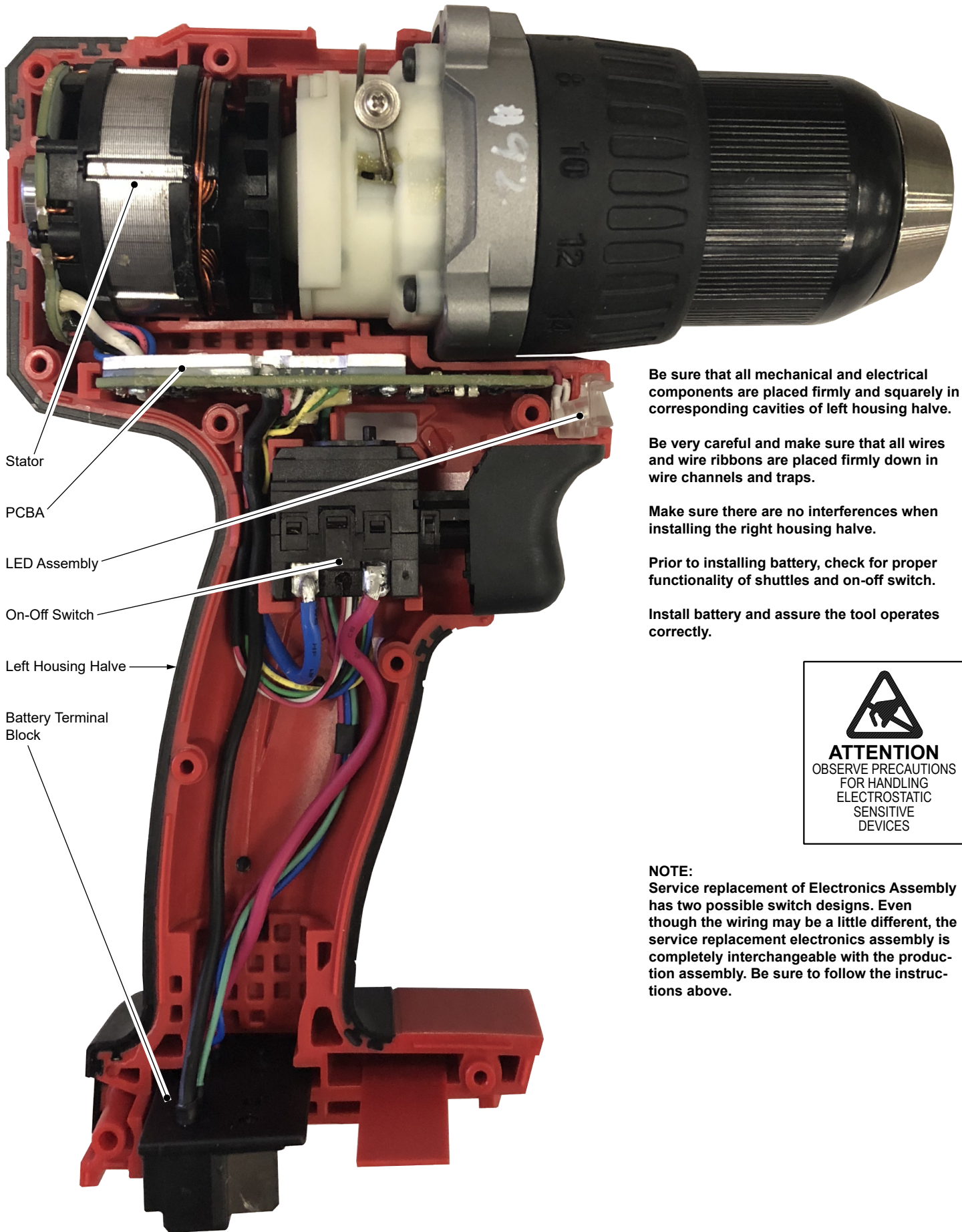

FIG.	PART NO.	DESCRIPTION OF PART	NO. REQ.
1	05-88-0202	M6.0 x 13mm LH Phillips Chuck Screw	(1)
2	42-66-2801	1/2" Keyless Chuck	(1)
3	06-82-7336	M4 x 20mm Pan Hd. Plastite T-10 Screw	(4)
4	14-29-2701	Gearbox Assembly	(1)
4a	-----	Gearbox	(1)
5	45-24-1002	Speed Selector Shuttle	(1)
6	05-81-0542	M2.3 Pan Washer Hd. Phillips ST Screw	(2)
7	42-42-6001	Forward/Reverse Shuttle	(1)
8	44-10-0195	Speed Change Lever	(1)
9	06-82-5315	M3 x 26mm Pan Hd. T-10 Plastite Screw	(1)
10	06-82-1080	M3 x 14mm Pan Hd. T-10 ST Screw	(8)
11	31-44-4014	Housing Assembly	(1)
11a	-----	Left Housing Halve - Support	(1)
11b	-----	Right Housing Halve - Cover	(1)
12	16-07-1007	Rotor Assembly	(1)
13	14-20-1002	Electronics Assembly	(1)
14	42-70-0950	Belt Clip Kit	(1)
14a	06-82-5275	6-32 x 7mm Pan Hd Taptite T-15 Screw	(1)
14b	-----	Belt Clip	(1)
15	42-55-5010	Blow Molded Carrying Case	(1)
16	12-20-0129	Service Nameplate	(1)

SCREW TORQUE SPECIFICATIONS				
FIG.	PART NO.	WHERE USED	SEAT TORQUE	
			(KG/CM)	(IN/LBS)
1	05-88-0202	Gearbox Spindle	104-115	90-99
2	42-66-2801	Gearbox Spindle	288-345	250-299
3	06-82-7336	Gearbox	9-11	7-9
6	05-81-0542	Gearbox	Lightly hand tighten	
9	06-82-5315	Right Housing Halve	9-11	7-9
10	06-82-1080	Right Housing Halve	9-11	7-9
14a	06-82-2500	Belt Clip	12-16	10-12



Stator

PCBA

LED Assembly

On-Off Switch

Left Housing Halve

Battery Terminal Block

Be sure that all mechanical and electrical components are placed firmly and squarely in corresponding cavities of left housing halve.

Be very careful and make sure that all wires and wire ribbons are placed firmly down in wire channels and traps.

Make sure there are no interferences when installing the right housing halve.

Prior to installing battery, check for proper functionality of shuttles and on-off switch.

Install battery and assure the tool operates correctly.



NOTE:
Service replacement of Electronics Assembly has two possible switch designs. Even though the wiring may be a little different, the service replacement electronics assembly is completely interchangeable with the production assembly. Be sure to follow the instructions above.